



Truck and Bus Programme

February 2009

Europe



Table of Content

	Page
Corporate Profile	2
Technologies	3
Environmental, Economic and Social Responsibilities	7
Market Segments	8
Pattern Range	
Summary and Legend	10
Long Haul	12
Regional	16
Mixed Service	20
Urban	24
Naming convention	25
Product Range	26
Tyres in Development	29
Recommendations for the use of GT Radial Truck Tyres	30
Servicing of Tube type tyres on multi piece rims	31
Designations, Load and Speed Index	34
Technical Specifications	35
Load Capacity by Axle(kg) and Pressure(bar)	36
Regrooving of Radial Tyre	42
Contact	46

Corporate Profile

GITI Tire manufacture a comprehensive range of products distributed through an extensive international sales network and currently exported to over one hundred countries around the world.

GITI Tire currently has seven manufacturing plants operating at the very highest global standards in terms of production quality and capacity. GITI Tires's comprehensive product portfolio includes Passenger Car, Ultra High Performance, Commercial Light Truck, 4x4/SUV and Truck and Bus.

Why GITI Tire



GITI Tire are at the forefront of new technology, by helping to reduce road noise, and improve fuel economy by reducing rolling resistance, and to provide good casing retreadability and tyre life. GITI Tire has implemented a comprehensive quality control system at all manufacturing plants. Strict quality control measures ensure that the quality of raw materials meet the GITI stringent quality standards and specifications.



GITI Tire is fully committed to maintaining the very highest standard of quality control procedures, and has obtained ISO9001:2000 and ISO/TS16949:2002 accreditation for all of five key manufacturing plants. In addition, all plants have obtained or are in the process of obtaining ISO14001 Environmental Management System Accreditation.



All TBR and PCR tyres produced by GITI Tire for export to Europe satisfy standards for all the European Union legal directives and standards. E-mark Safety and Noise Certification tests are performed and accredited by TÜV Rheinland Group. Approximately 450 employees are involved in research and development activities at the GITI Research Centre, which oversees the R&D activities of GITI's five tyre plants. GITI'S research and development efforts have enabled the development of European Mission Matched products and have also helped improve product design and production technology to maintain a leading market position. In addition to in-house research and development capabilities, GITI Tire also collaborates with various leading universities and top research institutions such as of Science and Technology of China, National Quality Examination Centre for Rubber Tyre, Smithers Research Laboratories, USA and TUV Automotive GmbH Tire/Wheel Test Centre in Germany.



GITI Tire has made a significant investment in a tyre testing facility at the internationally acclaimed MIRA Ltd (Motor Industry Research Association). The MIRA technical operation provides development and evaluation support to GITI's Research and Development Centre and is employed in the development of tyre products for both local and worldwide application. MIRA is unique in that it provides the widest range of testing facilities and laboratories for the development of tyres for all types of vehicles.

TECHNOLOGIES































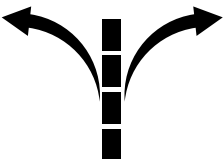

Best price per Kilometer



Driver satisfaction



Reliability

Features				Application	Found on
 Equal Force Carcass EFC is GITI Tire's specially designed carcass technology enabling an optimal tyre footprint and equal force distribution resulting in both better control and regular tread wear	*	*	*	   	ALL
 Duo Filler is the combination of two different bead fillers: Hard and Soft to produce both comfort and robustness.	*	*	*	   	ALL
 Sidewall Protector Ribs protect the casing from curbing & sidewall damage	*		*	   	ALL
 Cap & Base Tread design Cap layer provides wear resistant qualities and Base insulates the casing against heat for cooler running.	*		*	   	ALL
 Stone Ejector prevents stone penetration inside the belt.	*	*	*	   	GT279 GT269 GT988+ GT979 GT876
 Ex-Depth Solid Shoulder increased volume on the shoulder area resulting in more even wear especially on long haul applications.	*	*		 	GT279 GT269 GT268 GT276 GT988+ GT259 GT888 GT979 GT867
 Ex-Depth Open Shoulder allows greater traction and improved resistance to heel and toe wear.	*	*		 	GT876 GT688 GT676 GT679 GT629 GT659 GT678 GT686



Equal Force Carcass

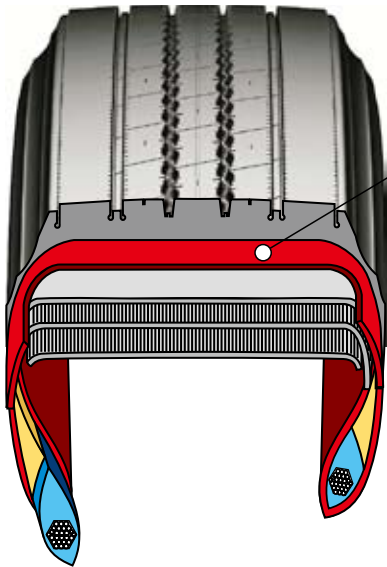

EFC is GITI Tire's specially designed carcass technology enabling an optimal tyre footprint and equal force distribution resulting in both better control and regular tread wear.

Improved regular wear means higher removal mileage

Better control and less noise

 Saves money through lower cost per kilometer

 Driver satisfaction



DUO FILLER is the combination of two bead fillers: Hard and Soft

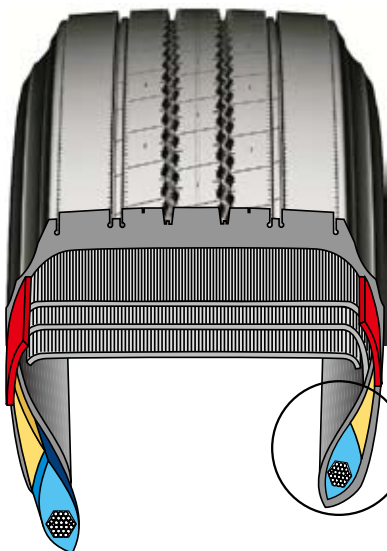

Soft Bead filler helps provide a more comfortable ride and smoother handling

 Driver satisfaction

Hard Bead Filler is stiff for better durability

 Reliability



Sidewall Protection Ribs



Cap & Base Tread design

Cap layer provides wear resistant qualities and the base rubber between the top layer and the casing includes a special cooler running formulation insulating casing from heat build up.

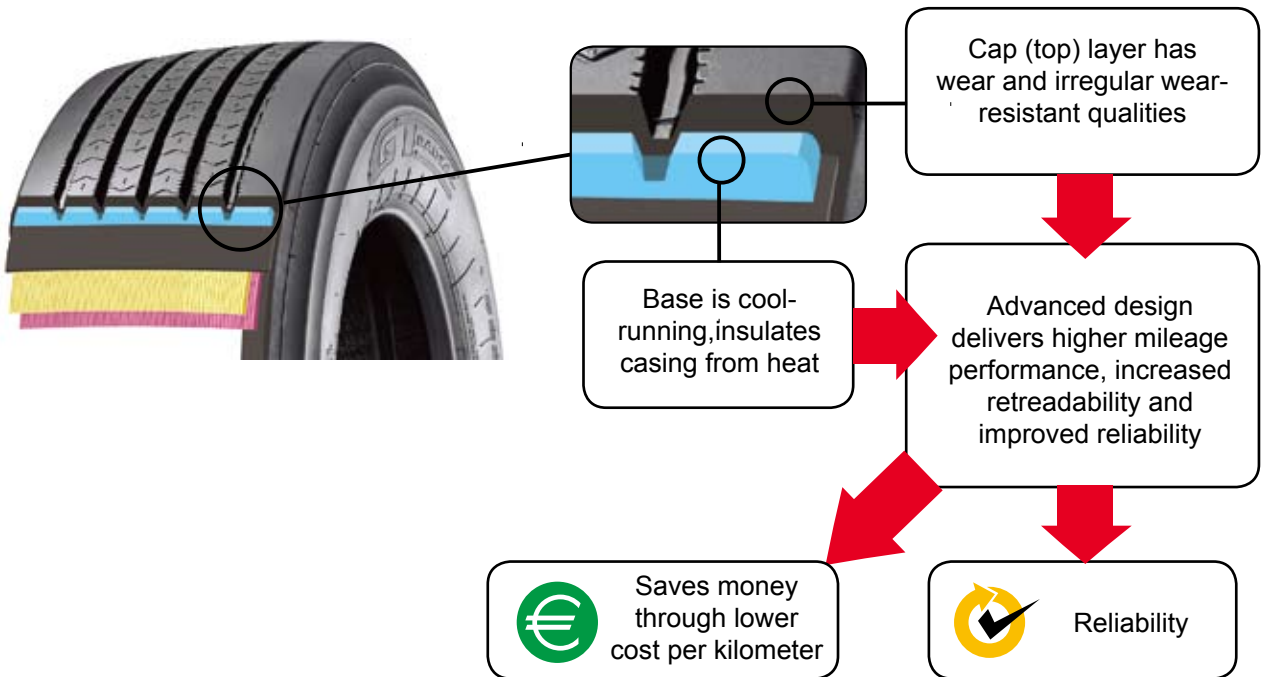

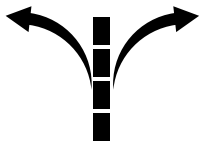

Stone Ejector

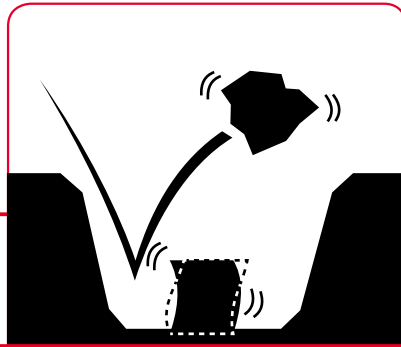
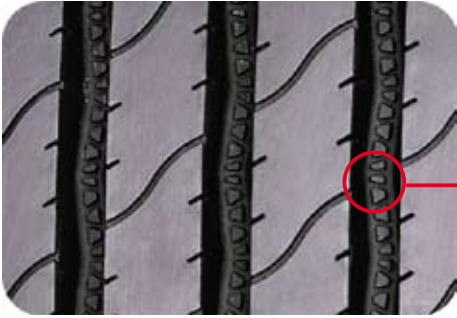

€ Saves money through longer tyre life

✓ Reliability

😊 Driver satisfaction

Stone Ejector prevents stone trapping in the grooves and reduces the risk of penetration into the tyre belts, which can cause rust inside the tyre construction and significantly reduce tyre performance.



Tyre Belt



Ex-Depth Solid Shoulder increased volume on the shoulder area resulting in more even wear especially on long haul applications.

😊 Driver satisfaction

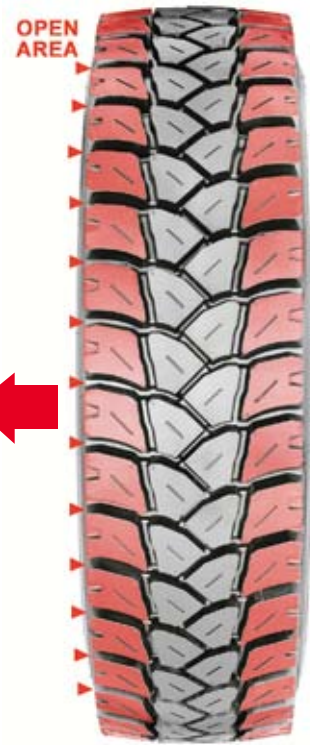

Ex-Depth Open Shoulder allows greater traction and improved resistance to heel and toe wear.

😊 Driver satisfaction

Environmental, Economic and Social Responsibility

The GITI Tire Research and Development Centre is active in finding innovative solutions to limit the impact of its products on the environment.

Robust Casing

GITI Tire's robust and durable casing is designed to absorb unevenness on the road surface by reducing unwanted movement on the road-tread contact area

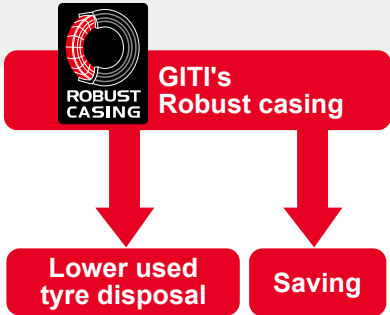

The Best Price Per Kilometer

Advanced tread patterns and compounds combined with re-groovable and retreadable casings designed to deliver the best price per kilometer for the Fleet and reduce the number of disposable carcasses within the environment

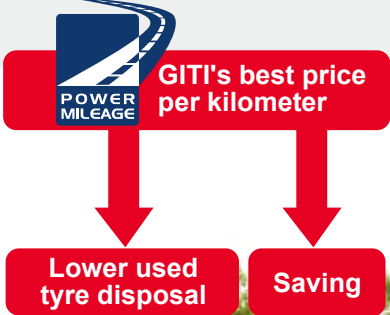

GITI Tire Corporation partners with Conservation International to protect forests in Indonesia and China

The program will protect the habitat of threatened species such as the Sumatran Orang-utan in Indonesia and Pandas in Southwest China and replant forest areas while helping reduce the levels of atmospheric carbon that cause climate change. For the first year, the investment will offset the corporation's overall carbon emissions in 2008.



MARKET SEGMENTS

Tyres designed and developed for specific application

Using the latest design and manufacturing technology GITI Tire has developed a range of Mission Matched tyres to meet the ever increasing demands of today's European transport operations.

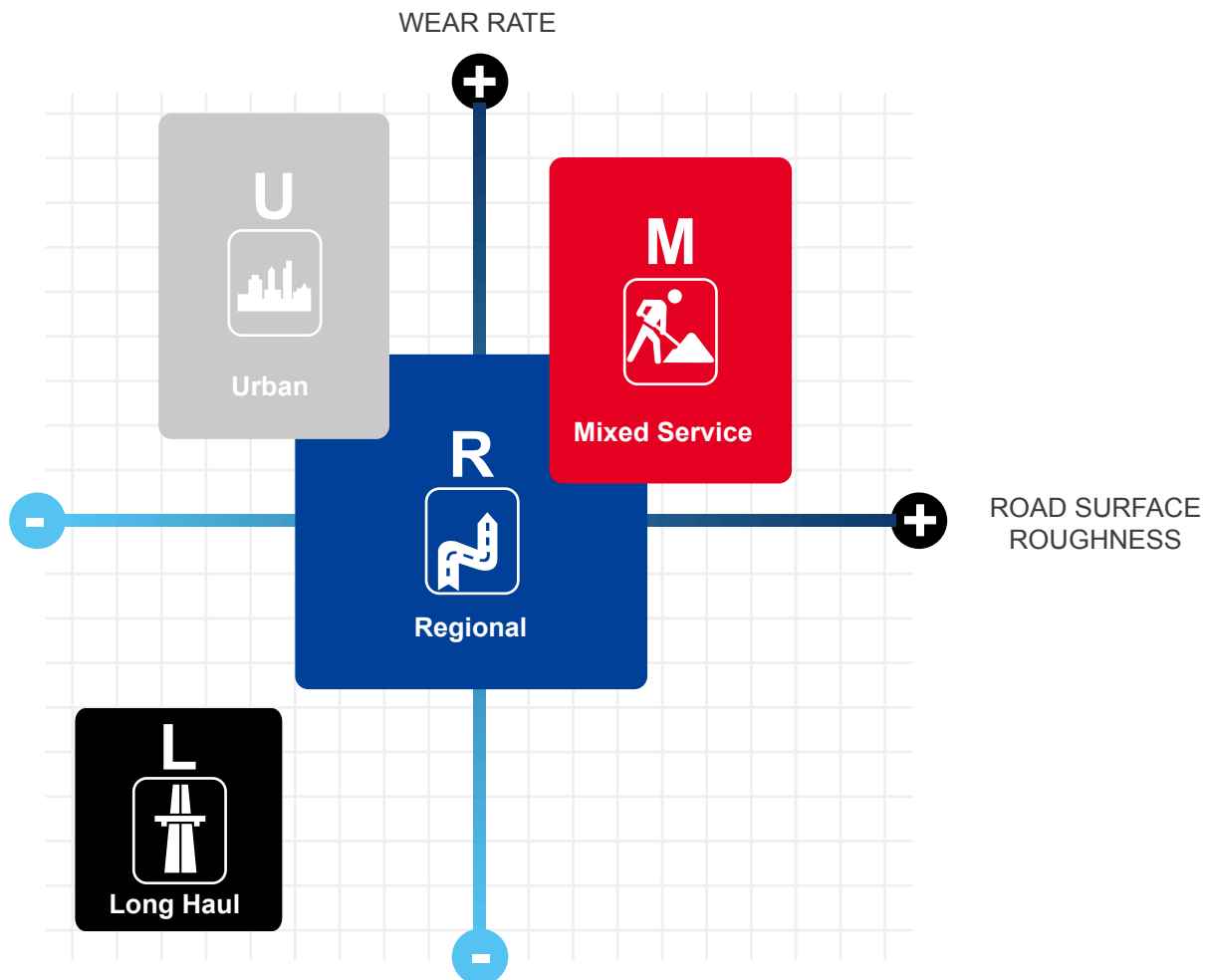

This diagram gives you details of all our ranges according to the use.

Product details given for information only. GITI Tire reserves the right to modify details of products and services at any time and without notice.

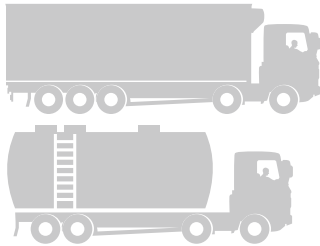

Long Haul Operation:

- Motorways and trunking
- Long distance journeys mainly on motorways and A roads
- Constant speeds with minimal braking and accelerating
- Well paved road conditions

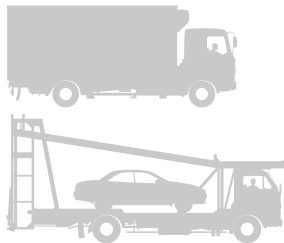

Regional Operation:

- Shorter journeys on regional national roads
- Flexible in a variety of applications
- Frequent braking, acceleration and turning
- Mainly on paved road, occasional use on unpaved road conditions



Mixed Service Operation:















- Frequent use both on and off road
- Higher loads
- Increase risk of damage from road conditions



Urban Operation:

- Constant stop and go operating conditions
- Frequent speed changes and turning
- Increased risk of damage from curbing impacts

PATTERN RANGE

POSITION	ROAD	Long Haul			
 Steer	     GT259-pg.15 GT269-pg.15 GT279-pg.15 GT288-pg.13				
 Drive	   GT629-pg.16 GT669-pg.16 GT679-pg.16				
 Trailer	   GT979-pg.17 GT279-pg.17 GT988-pg.17				

Legend

STEER



DRIVE



ALL POSITION



TRAILER



Regional



GT279-pg.17

GT268-pg.19

GT879-pg.19

GT276-pg.19

Mixed service



GT876-pg.23

GT01-pg.23

Urban



GT867-pg.27



GT669-pg.16

GT659/GT659+
pg.20

GT678-pg.20

GT688-pg.20



GT676-pg.24

GT686-pg.24

GT01-pg.24

GT867-pg.27



GT268-pg.21

GT978-pg.21

GT888-pg.21

GT879-pg.21



GT876-pg.25

GT01-pg.25



GT867-pg.27

Long Haul



Mixed Service



Regional



Urban



M+S M+S Marked

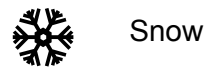

Snow



Fuel Efficient



Directional



Long Haul



Operation:

- Motorways and trunking
- Long distance journeys mainly on motorways and A roads
- Constant speeds with minimal braking and accelerating
- Well paved road conditions



STEER AXLE



- Excellent stability
- Slow and even wear
- Low aspect ratio

GT259



- High resistance to damage and impacts
- Excellent stability
- Reduced noise

GT269



- High mileage performance
- Slow and even wear
- Excellent stability

GT279



- High mileage performance
- Slow and even wear

GT288



Dimension	GT259	GT269	GT279	GT288
245/70R19.5			136/134M	
285/70R19.5			146/144L	
11.00R20			149/145K	
12.00R20			154/151K	
10R22.5			141/139M	
11R22.5			148/145M	
12R22.5				152/148M
385/55R22.5	158/-L			
385/65R22.5		158/-L		
255/70R22.5			140/137M	
275/70R22.5			148/145M	
315/70R22.5			154/150L	
295/80R22.5			152/148M	
315/80R22.5			154/151M	

Legend



Some sizes applicable for All position Bus



Better fuel consumption

Long Haul 



DRIVE AXLE



GT629

- Excellent all season traction
- Slow and even wear
- Reduced noise



GT669

- High mileage performance
- Excellent traction
- Slow and even wear
- Resistant to stone drilling



M+S



GT679

- Excellent traction
- Reduced noise
- High mileage performance



M+S

Dimension	GT629	GT679	GT669
215/75R17.5		126/124M	
235/75R17.5		132/130M	
265/70R19.5		140/138M	
285/70R19.5		144/142M	
10.00R20 *			146/143K
11.00R20 *			149/145K
11R22.5		148/144L	
12R22.5		152/148L	
315/70R22.5		154/150L	
295/75R22.5		144/141L	
295/80R22.5	152/148M	152/148M	
315/80R22.5		154/151M	
11R24.5		149/146L	

Legend

M+S Provides excellent traction in Mud and Snow conditions



Snow

* In development



- Improved resistance to heat build up
- Reduced rolling resistance

GT979



- High mileage performance
- Slow and even wear

GT279



- Improved resistance to heat build up
- High mileage performance
- Reduced rolling resistance
- Improved resistance to damage and impacts

GT988+



Dimension	GT979	GT279	GT988+
245/70R17.5			143/141J
215/75R17.5			135/133J
235/75R17.5			143/141J
245/70R19.5		141/140J	
285/70R19.5			150/148J
11R22.5	148/144L		
385/55R22.5			160/-K
385/65R22.5			158/-L
255/70R22.5	140/137L		

Legend



Better fuel consumption



Regional



Operation:

- Shorter journeys on regional national roads
- Flexible in a variety of applications
- Frequent braking, acceleration and turning
- Mainly on paved road, occasional use on unpaved road conditions



GT268

- Improved resistance to heat build up
- Reduced rolling resistance
- Good grip and braking properties



GT879

- High mileage performance
- Improved resistance to heat build up
- Good grip and braking properties
- Excellent stability



GT276

- Superb resistance to abrasion
- Improved endurance and reliability
- Slow and even wear



GT279

- High mileage performance
- Slow and even wear



Dimension	GT268	GT879	GT276	GT279
215/75R17.5	126/124M	126/124M		
235/75R17.5		132/130M 143/141J		
265/70R19.5		140/138M 143/141J		
10.00R20		146/143K		146/143K
11.00R20		149/145K		
12.00R20		154/151K		
9R22.5	136/134M			
11R22.5		148/145M	148/145M	
12R22.5			152/148L	
12R22.5		152/148M		
13R22.5			154/150L	
295/80R22.5			152/148k	
295/80R22.5		152/148M		
315/80R22.5			154/151K	

Legend



Some sizes applicable for Steer axle Bus

Regional



DRIVE AXLE



GT678

M+S

- Good resistance against perforations and tearing
- Reduced stone trapping
- Excellent self cleaning properties



**GT659
GT659+**



- High mileage performance
- Excellent all season traction
- Slow and even wear



GT688

M+S

- Excellent all season traction
- Good stability



GT669

- High mileage performance
- Excellent traction
- Slow and even wear
- Resistant to stone drilling

Dimension	GT678	GT659	GT659+	GT688	GT669
7.50R16 LT	122/118K				
8.25R16 LT	126/122K				
245/70R19.5	136/134M				
265/70R19.5	140/138M				
285/70R19.5	144/142M				
10R22.5				141/139M	
12R20*					154/151K
12R22.5			152/148L		
315/70R22.5			154/150L		
295/80R22.5			152/148M		
315/80R22.5		154/150M			

* In development

Legend

M+S Provides excellent traction in Mud and Snow conditions



Some sizes applicable for Drive axle Bus



Snow



GT268

- Improved resistance to heat build up
- Reduced rolling resistance
- Good grip and breaking properties



GT978

- High mileage performance
- Good stability
- High resistance to damage



GT888

- Slow and even wear
- Reduced rolling resistance
- High resistance to damage

M+S



GT879

- High mileage performance
- Improved resistance to heat build up
- Good stability

Dimension	GT268	GT978	GT888	GT879
215/75R17.5	126/124M			
235/75R17.5				143/141J
265/70R19.5				143/141J
9R22.5	136/134M			
385/65R22.5		160/158 L/K	158/160 L/K	

Legend

M+S Provides excellent traction in Mud and Snow conditions



M



Mixed
Service



Operation:

- Frequent use both on and off road
- Higher loads
- Increase risk of damage from road conditions



GT876



- High resistance to damage
- Anti cut and chip compound
- Robust casing construction



GT01



- Excellent traction and stability
- Anti cut and chip compound
- High mileage performance

Dimension	GT876	GT01
9.00R20		144/142K
10.00R20		146/143K
11.00R20		149/145K
12.00R20		154/149K
11R22.5		148/144M
13R22.5		154/150L
315/80R22.5		154/151L
12.00R24		156/153K
385/65R22.5	158/-L	
425/65R22.5	165/-K	
445/65R22.5	169/-K	

Legend

M+S Provides excellent traction in Mud and Snow conditions





DRIVE AXLE



GT676

M+S

- Excellent traction and self cleaning properties
- Enhanced resistance to tread tearing
- Slow and even wear



GT686

- High mileage performance
- Excellent traction and self cleaning properties
- Enhanced resistance to tread tearing



GT01

M+S

- Excellent traction and stability
- Anti cut and chip compound
- High mileage performance

Dimension	GT676	GT686	GT01
9.00R20			144/142K
10.00R20	146/143K		146/143K
11.00R20	149/145K		149/145K
12.00R20			154/149K
11R22.5			148/144M
13R22.5	154/150K	154/150K	
13R22.5			154/150L
275/70R22.5	148/145K		
315/80R22.5			154/151L
315/80R22.5	156/150K	156/150K	
12.00R24	156/153K		156/153K

Legend

M+S Provides excellent traction in Mud and Snow conditions

 Some sizes applicable for Drive axle Bus

 Directional



GT876

 M+S

- High resistance to damage
- Anti cut and chip compound
- Robust casing construction



GT01

M+S

- Excellent traction and stability
- Anti cut and chip compound
- High mileage performance

Dimension	GT876	GT01
9.00R20		144/142K
10.00R20		146/143K
11.00R20		149/145K
12.00R20		154/149K
11R22.5		148/144M
13R22.5		154/150L
315/80R22.5		154/151L
12.00R24		156/153K
385/65R22.5	158/-L	
425/65R22.5	165/-K	
445/65R22.5	169/-K	

Legend

M+S Provides excellent traction in Mud and Snow conditions

 Snow



All position axle



Urban



Operation:

- Constant stop and go operating conditions
- Frequent speed changes and turning
- Increased risk of damage from curbing impacts



GT867



M+S

- High mileage performance
- Reinforced side wall protection
- Excellent all season all position usage

Dimension

11R22.5

275/70R22.5

295/80R22.5

GT867

148/145J

148/145J

152/148J

Legend

M+S Provides excellent traction in Mud and Snow conditions



Snow

NAMING CONVENTION

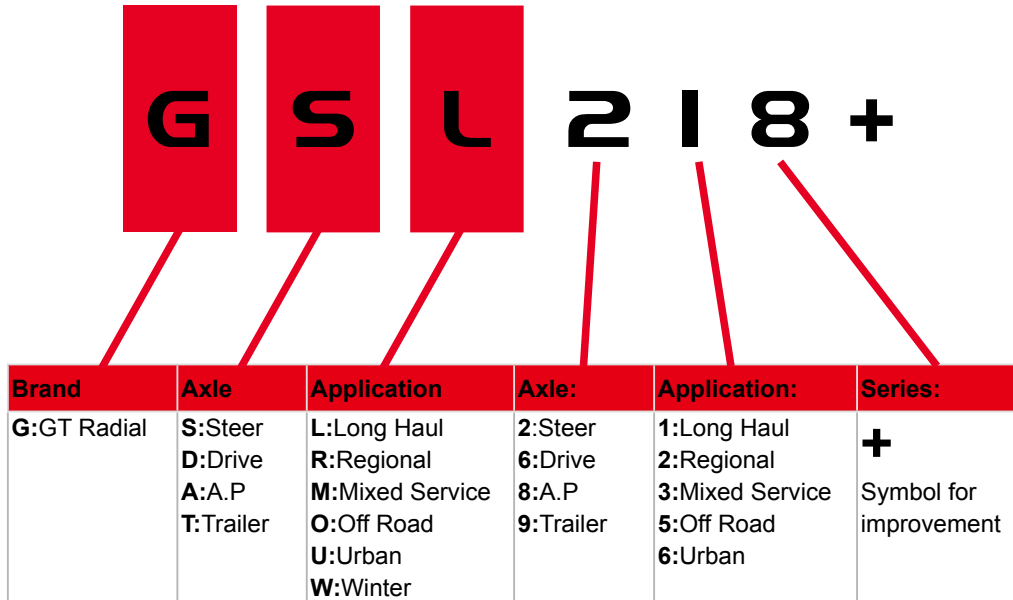

A.P = All Position

NEXT ►

- Product Range
- Tyres in Development
- Recommendations for the use of GT Radial Truck Tyres

PRODUCT RANGE



DIMENSION	GT259	GT269	GT279	GT288	GT629	GT669	GT679	GT979	GT988+
215/75R17.5							126/124M		
215/75R17.5									135/133J
235/75R17.5							132/130M		143/141J
245/70R17.5									143/141J
245/70R19.5			136/134M 141/140						
265/70R19.5							140/138M		
285/70R19.5			146/144L				144/142M		150/148J
10.00R20						146/143K*			
11.00R20			149/145K			149/145K*			
12.00R20			154/151K						
10R22.5			141/139M						
11R22.5			148/145M				148/144L	148/144L	
12R22.5				152/148M			152/148L		
385/55R22.5	158/-L								160/-K
385/65R22.5		158/-L							158/-L
255/70R22.5			140/137M					140/137L	
275/70R22.5			148/145M						
315/70R22.5			154/150L				154/150L		
295/75R22.5							144/141L		
295/80R22.5			152/148M		152/148M		152/148M		
315/80R22.5			154/151M				154/151M		
11R24.5							149/146L		

* In development



DIMENSION	GT268	GT276	GT279	GT659	GT659+	GT669	GT678	GT688	GT879	GT888	GT978
7.50R16 LT							122/118K				
8.25R16 LT							126/122K				
215/75R17.5	126/124M								126/124M		
235/75R17.5									132/130M 143/141J		
245/70R19.5							136/134M				
265/70R19.5							140/138M		140/138M 143/141J		
285/70R19.5							144/142M				
10.00R20			146/143K						146/143K		
11.00R20									149/145K		
12.00R20						154/151K*			154/151K		
9R22.5	136/134M										
10R22.5								141/139M			
11R22.5		148/145M							148/145M		
12R22.5		152/148L			152/148L				152/148M		
13R22.5		154/150L									
385/65R22.5										158/-L	158/-L
315/70R22.5					154/150L						
275/80R22.5											
295/80R22.5		152/148k			152/148M				152/148M		
315/80R22.5		154/151K		154/150M					154/151M		
12.00R24		156/153K							156/153K		





* In development

PRODUCT RANGE



DIMENSION	GT01	GT676	GT686	GT876		GT867
9.00R20	144/142K					
10.00R20	146/143K	146/143K				
11.00R20	149/145K	149/145K				
12.00R20	154/149K					
11R22.5	148/144M					148/145J
13R22.5	154/150L	154/150K	154/150K			
385/65R22.5				158/-L		
425/65R22.5				165/-K		
445/65R22.5				169/-K		
275/70R22.5		148/145K				148/145J
295/80R22.5						152/148J
315/80R22.5	154/151L	156/150K	156/150K			
12.00R24	156/153K	156/153K				

TYRES IN DEVELOPMENT

Application		Position	Pattern	Size
	Long Haul	Steer	GT279	285/70R19.5
		Steer	GT259	385/65R22.5
		Drive	GDL617	295/80R22.5
				315/70R22.5
				315/80R22.5
				315/60R22.5
Trailer	GT988+	235/75R17.5		
245/70R17.5				
285/70R19.5				
445/45R19.5				
	Regional Bus	All	GAR821	295/80R22.5
	Regional	Steer	GSR221	315/80R22.5
				315/70R22.5
				295/80R22.5
				315/60R22.5
				205/75R17.5
				225/65R17.5
	245/70R17.5			
Drive	GDRxxx	205/75R17.5		
		225/75R17.5		
		245/70R17.5		
Drive	GDR621	315/80R22.5		
Drive	GT659+	315/80R22.5		
Trailer	GTR921	275/70R22.5		
265/70R19.5				
	Mixed Service	Drive	GT686	295/80R22.5
		All	GAM831	13R22.5
315/80R22.5				
	Urban	All	GAU811	275/70R22.5

Recommendations for the use of GT Radial Truck Tyres

SAFETY

Important instructions for safe inflation



Tyre pressure directly influences tyre life and safety

Over-inflation reduces:

- Comfort
- Grip
- Braking distance
- Tyre life span, particularly on drive axle tyres.
- Safety

Under-inflation leads to:

- Reduced vehicle handling and safety
- A reduction in casing retreadability
- An increase of rolling resistance consequently of fuel consumption.

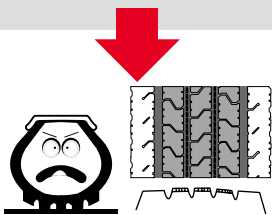

Over-inflation

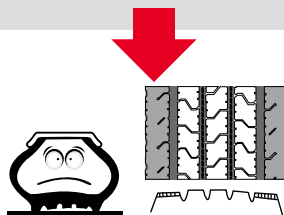

Under-inflation

Effect of inflation pressure on tire life

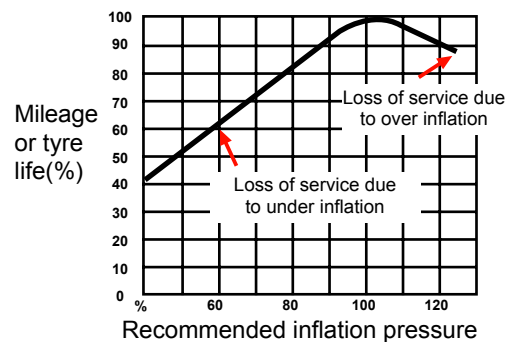

ADVICE BEFORE INFLATION

- 1 Weigh your vehicle and its load, axle by axle, to determine tyre pressure. (pg.38-43)
- 2 Measure the pressure when cold (when the vehicle has been stationary for several hours): pressures must be checked at regular intervals and during each service.
- 3 Important safety instruction: pressure increases when the vehicle is in motion, never reduce the pressure of a hot tyre.
- 4 Pressure gauges: must be accurate, handled with care and calibrated regularly



Caution:

Driving with insufficient pressure can damage your tyres. After having driven with an underinflated tyre, do not re-inflate tyres: have your tyres fully checked over by an expert.

INFLATION METHOD



With inflation cage

- Place the tyre vertically in the inflation cage.
- Read the cage user manual.



Without inflation

Step1



Step2

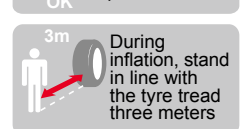

Servicing of Tube type tyres on Multi piece rims

A

Firstly, it is important to understand that the various tasks involved in the stripping and rebuilding of multi-piece wheels are far more hazardous than those on single piece wheels. To eliminate potentially fatal incidents when working with multi-piece rims, be sure to understand and follow all procedures and safety instructions according to the wheel manufacturer.

B

There are several different types of multi-piece rim and it is **ESSENTIAL** that component parts are **NOT** mixed between the different types. When demounting a tyre from a multi-piece rim, always keep loose flanges and locking rings together with the rim base from which they were removed.

C

Good mounting practices and procedures are also important in order to obtain optimum tyre performance and operating efficiency.

- **Scope.**

These guidelines apply to the servicing of vehicle wheels mounted with tube-type tyres fitted to multi-piece rims.

- **Definition.**

'Multi piece rim' (sometimes referred to as 'split rim') means a vehicle commercial wheel rim consisting of two or more parts, one of which is a locking ring designed to hold the tyre on the rim by tension on interlocking components when the tyre is inflated.



Do not mount or demount a multi piece wheel / rim without fully understanding sections 1 - 13 (explain on the next page), or before receiving proper training.

Servicing of Tube type tyres on Multi piece rims

- 1 Before demounting from the rim base, tyres MUST be completely deflated by removal of the valve core.
- 2 Before the wheel is removed from the vehicle's axle, the valve core must be removed and the tyre fully deflated when either condition 'a' or 'b' below is noted:
A. The tyre has been operated underinflated at 80% or less, of its recommended pressure, OR
B. There is discernible or suspected damage to the tyre or wheel components.
- 3 Before assembly, wheel components should be inspected, and damaged rim components must not be reused. Mating surfaces must be free of dirt, surface rust, scale and rubber buildup before mounting a tube type tyre to a rim base. Use a de-scaling hammer or similar to remove rust build up, finishing with a hand held wire brush. NOTE – ALWAYS wear P.P.E. (Personal Protective Equipment) – especially eye protection and ear protection during this task.
- 4 Using a vacuum cleaner, ensure the tyre is completely clean inside and free from all debris and dust.
- 5 Using talcum powder or similar, lightly powder the tube and flap before assembling into tyre. This assists in the “rounding out” of the tube and avoids chafing when in service. Do not allow the tube or flap to lay on a dirty ground surface as this will cause contamination and potential failure in service!
- 6 Apply a non water based rubber lubricant to bead area of the tyre and rim base mating surfaces upon wheel assembly. This assists in correct seating of tyre when inflating.
- 7 Air pressure must not exceed 1 bar (15 p.s.i) whilst seating the flange and locking ring when a tyre is being partially inflated without a restraining device.
- 8 Once all components are seated correctly with pressure not exceeding one bar pressure, the built up tyre / wheel assembly should be placed vertically into a restraining device such as a suitable safety cage, with the locking ring facing the wall. Once in position, final inflation to the recommended operating pressure can take place. See image right. Always check the cage manufactures recommendations.
- 9 The tyre inflation gauge should have a minimum 3 meters of hose between the valve connector and the hand held gauge, and the operator should stand this distance away from the tyre in line with the tread – see image right.
- 10 Whilst the tyre is pressurized, components must not be struck or forced to correct the seating of flanges or locking rings.



- 11** There should be no contact between the person performing the task or unit of equipment and a restraining device during tyre inflation.
- 12** After inflation, tyres, rims and locking rings should be visually inspected while within the restraining device to ensure correct seating and locking. If adjustment is necessary the tyre must first be deflated by valve core removal and the process started again.
- 13** Once finally inflated to the correct operating pressure, the tyre should be left in the restraining device for a minimum of five minutes before re-checking final pressure. NOTE - there is often a settling down in tube type tyres that produces some pressure loss. This is mainly caused by trapped air between the tube and tyre during assembly. After final pressurization fit a high pressure valve cap.



NOTES

- Rims, flanges and locking rings should never be repaired by heating or welding.
- Never inflate a tyre beyond the maximum pressure recommended by the manufacture.
- Never work on an inflated tyre.
- If a tyre has been run flat or grossly underinflated, it must be removed from the rim and examined by a qualified person before re-inflating.
- Remember, if the tyre or any of the components show any signs of damage that might cause failure on inflation or failure when back in service, do not attempt to rebuild the assembly.
- Never try to adjust incorrectly seated components by hammering whilst the tyre is inflated.
- If there is any doubt over the integrity of component parts always deflate the assembly and remove the tyre.

Designations, Load and Speed index

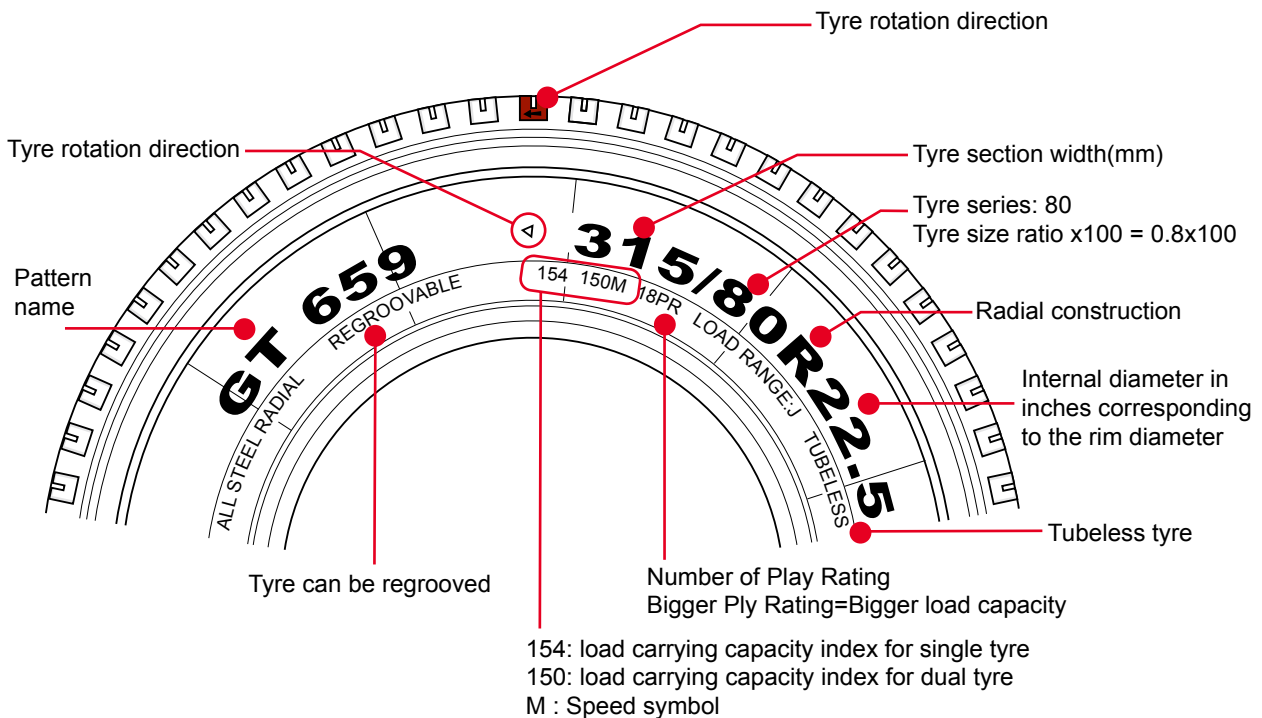

Refer to the Speed Symbols and Load Capacity Index tables below



Before fitting, it is essential to check the different markings to ensure that the tyres meet the maximum load and speed possibilities and/or the regulations in force.

Speed symbols







SI	km/h
B	50
C	60
D	65
E	70
F	80
G	90
J	100
K	110
L	120
M	130
N	140
P	150
Q	160
R	170

Load Capacity Index

LI	KG	LI	KG	LI	KG
115	1215	136	2240	157	4125
116	1250	137	2300	158	4250
117	1285	138	2360	159	4375
118	1320	139	2430	160	4500
119	1360	140	2500	161	4625
120	1400	141	2575	162	4750
121	1450	142	2650	163	4875
122	1500	143	2725	164	5000
123	1550	144	2800	165	5150
124	1600	145	2900	166	5300
125	1650	146	3000	167	5450
126	1700	147	3075	168	5600
127	1750	148	3150	169	5800
128	1800	149	3250	170	6000
129	1850	150	3350	171	6150
130	1900	151	3450	172	6300
131	1950	152	3550	173	6500
132	2000	153	3650	174	6700
133	2060	154	3750	175	6900
134	2120	155	3875	176	7100
135	2180	156	4000	177	7300

TECHNICAL SPECIFICATIONS

Tyre rotation direction

-  S Tyre section.
-  H Tyre height.
-  R Unloaded free diameter.
-  R' Loaded deflected radius.
-  D Rolling Circumference
-  E Min distance tyre sidewalls in twin fit
-  Tread depth

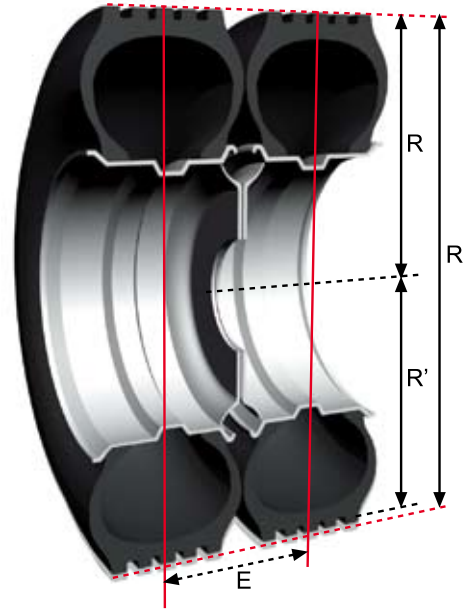
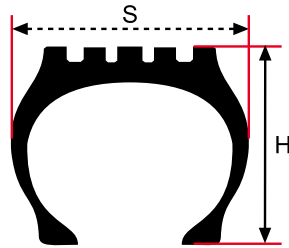

Load capacity variations according to speed

Speed (km/h)	Load Capacity Variation(%)						Pressure Balance(%)
	F	G	J	K	L	M	
0	+150	+150	+150	+150	+150	+150	40
5	+110	+110	+110	+110	+110	+110	40
10	+80	+80	+80	+80	+80	+80	30
15	+65	+65	+65	+65	+65	+65	25
20	+50	+50	+50	+50	+50	+50	21
25	+35	+35	+35	+35	+35	+35	17
30	+25	+25	+25	+25	+25	+25	13
35	+19	+19	+19	+19	+19	+19	11
40	+15	+15	+15	+15	+15	+15	10
45	+13	+13	+13	+13	+13	+13	9
50	+12	+12	+12	+12	+12	+12	8
55	+11	+11	+11	+11	+11	+11	7
60	+10	+10	+10	+10	+10	+10	6
65	+7.5	+8.5	+8.5	+8.5	+8.5	+8.5	4
70	+5.0	+7.0	+7.0	+7.0	+7.0	+7.0	2
75	+2.5	+5.5	+5.5	+5.5	+5.5	+5.5	1
80	[0]	4.0	+4.0	+4.0	+4.0	+4.0	0
85		2.0	+3.0	+3.0	+3.0	+3.0	0
90		[0]	+2.0	+2.0	+2.0	+2.0	0
95			+1.0	+1.0	+1.0	+1.0	0
100			[0]	0	0	0	0
110				[0]	0	0	0
120					[0]	0	0
130						[0]	0

The coefficients in this table are those of the ETRTO standard and are given for information only.









Contact us for all load capacities greater than the basic load limits given by tyre markings and used in this brochure. When the coefficients in these tables lead to pressure greater than 10 bars, you must reduce the maximum load capacity to an amount which corresponds to a maximum pressure of 10 bars.

If you wish to use pressure greater than 10 bars, consult us for the tyres, check the maximum resistance of rims with your rim manufacturer and comply with regulations in force for fitting and use. The coefficients indicated in this table are taken from the ETRTO.

In urban and suburban traffic (M3 – class I): + 15%, when the average speed is under 40 km/h.

In intercity traffic (M3 – class II): + 10%, when speed is limited to 60 km/h.









TECHNICAL SPECIFICATIONS

Bead	Series	SIZE	Pattern	Index	Index 2	PR	Type		APPROVED RIMS	 mm	 mm	 mm	 mm	 mm	Min Dual	 kg max	 kg	Index		
16	100	7.50R16	GT678	122/118K		14	TT	6.00G	5.50F;6.50H	215	802	375	2446	12.5	242	1500	1320	122		
			GT886	122/118K		14	TT							12.5				118		
16	100	8.25R16	GT678	126/122K		14	TT	6.50H	6.00G	235	860	397	2623	13.0	269	1700	1500	126		
			GT886	126/122K		14	TT							12.5				122		
17.5	75	215/75R17.5	GT268	126/124M		12	TL	6.00	6.75	211	767	360	2339	12.5	239	1700	1600	126		
			GT679	126/124M		12	TL							14.5				124		
			GT879	126/124M		12	TL							12.7						
17.5	75	215/75R17.5	GT988+	135/133 J		16	TL	6.00	6.75	211	767	360	2339	14.0	239	2180	2060	135 133		
17.5	75	235/75R17.5	GT679	132/130M		14	TL	6.75	7.50	233	797	373	2431	15.0	262	2000	1900	132		
			GT879	132/130M		14	TL							12.7				130		
17.5	75	235/75R17.5	GT268	143/141 J		16	TL	6.75	7.50	233	797	373	2431	13.5	262	2725	2575	143		
			GT879	143/141 J	(144/144F)	16	TL							12.7				(2800)	(2800)	141
			GT988+	143/141 J	(144/144F)	16	TL							13.5						
17.5	70	245/70R17.5	GT988+	143/141 J	144/144F	16	TL	7.50	6.75	248	789	367	2406	14.0	279	2725	2575	143		
																		(2800)	(2800)	141
19.5	70	245/70R19.5	GT279	136/134M		16	TL	7.50	6.75	248	839	392	2559	14.0	279	2240	2120	136		
			GT678	136/134M		16	TL											15.0	134	
19.5	70	245/70R19.5	GT279	141/140J		18	TL	7.50	6.75	248	839	392	2559	14.0	279	2575	2500	141		
																				140
19.5	70	265/70R19.5	GT678	140/138M		16	TL	7.50	6.75;8.25	262	867	411	2644	15.0	295	2500	2360	140		
			GT679	140/138M		16	TL							16.5				138		
			GT879	140/138M		16	TL							14.5						
19.5	70	265/70R19.5	GT879	143/141 J		18	TL	7.50	6.75;8.25	262	867	411	2644	14.5	295	2725	2575	143 141		
19.5	70	285/70R19.5	GT678	144/142M	(145/143L)	16	TL	8.25	7.50;9.00	283	895	413	2730	15.0	318	2800	2650	144		
			GT679	144/142M	(145/143L)	16	TL											16.0	(2900)	(2725)
19.5	70	285/70R19.5	GT279	146/144L	(144/142 M)	16	TL	8.25	7.50;9.00	283	895	413	2730	13.5	318	3000	2800	146		
																		(2800)	(2650)	144
19.5	70	285/70R19.5	GT988+	150/148J		18	TL	8.25	7.50;9.00	283	895	413	2730	13.5	318	3350	3150	150 148		
20	100	9.00R20	GT01	144/142 K		16	TT	7.0	7.5;7.00	259	1018	471	3105	15.0	297	2800	2650	144		
																				142
20	100	10.00R20	GT01	146/143K		16	TT	7.5	8.0;7.50	278	1052	493	3209	16.0	316	3000	2725	146		
			GT279	146/143K		16	TT							17.0				143		
			GT669	146/143K		16	TT							17.5						
			GT688	146/143K		16	TT							17.5						
			GT879	146/143K		16	TT							14.5						
20	100	11.00R20	GT01	149/145 K		16	TT	8.0	8.5;8.00	293	1082	507	3300	16.5	330	3250	2900	149		
			GT279	149/145 K		16	TT							15.0				145		
			GT669	149/145 K		16	TT							17.5						
			GT879	149/145 K		16	TT							14.5						
20	100	12.00R20	GT01	154/149 K		18	TT	8.5	8.50;9.00	315	1122	526	3422	17.0	344	3750	3250	154 149		
20	100	12.00R20	GT279	154/151 K		18	TT	8.5	8.50;9.00	315	1125	526	3431	17.5	344	3750	3450	154		
			GT669	154/151 K		18	TT							17.5				151		
			GT879	154/151 K		18	TT							14.5						

Load Capacity by AXLE(kg) and PRESSURE(bar)

"S=single D=Dual"	4.5	4.75	5	5.25	5.5	5.75	6	6.25	6.5	6.75	7	7.25	7.5	7.75	8	8.25	8.5	8.75	9
S	2010	2120	2230	2340	2450	2560	2670	2780	2890	3000									
D	3670	3850	4030	4210	4390	4570	4750	4930	5100	5280									
S	2320	2440	2560	2680	2800	2920	3040	3160	3280	3400									
D	3930	4160	4390	4620	4850	5080	5310	5540	5770	6000									
S	2280	2400	2510	2620	2740	2850	2960	3070	3180	3290	3400								
D	4300	4510	4730	4940	5150	5360	5570	5780	5990	6190	6400								
S					2920	3040	3160	3280	3400	3520	3640	3760	3880	4000	4120	4240	4360		
D					5480	5710	5940	6170	6400	6630	6860	7090	7320	7550	7780	8010	8240		
S	2560	2680	2800	2920	3040	3160	3280	3400	3520	3640	3760	3880	4000						
D	4960	5180	5400	5620	5840	6060	6280	6500	6720	6940	7160	7380	7600						
S					3620	3760	3890	4020	4150	4280	4410	4540	4670	4800	4930	5060	5190	5320	5450
D					6910	7180	7420	7660	7900	8140	8380	8620	8860	9100	9340	9580	9820	10060	10300
S					3500	3640	3780	3930	4070	4210	4350	4490	4630	4760	4900	5040	5180	5310	5450
D					6610	6880	7150	7420	7680	7950	8210	8480	8740	9000	9260	9520	9780	10040	10300
S			3040	3160	3280	3400	3520	3640	3760	3880	4000	4120	4240	4360	4480				
D			5720	5950	6180	6410	6640	6870	7100	7330	7560	7790	8020	8250	8480				
S					3470	3620	3760	3910	4050	4190	4320	4460	4600	4740	4880	5010	5150		
D					6760	7030	7310	7580	7850	8130	8400	8670	8930	9200	9470	9730	10000		
S			3350	3500	3650	3800	3950	4100	4250	4400	4550	4700	4850	5000					
D			6310	6590	6880	7160	7450	7730	8020	8300	8590	8870	9160	9440					
S					3620	3760	3890	4020	4150	4280	4410	4540	4670	4800	4930	5060	5190	5320	5450
D					6910	7180	7420	7660	7900	8140	8380	8620	8860	9100	9340	9580	9820	10060	10300
S			3760	3930	4000	4160	4320	4480	4650	4810	4970	5130	5280	5440	5600				
D			7300	7600	7570	7870	8180	8490	8790	9100	9400	9700	10000	10300	10600				
S			3850	4010	4170	4320	4480	4630	4790	4940	5090	5240	5400	5550	5700	5850	6000		
D			7190	7480	7780	8070	8360	8650	8930	9220	9510	9790	10070	10360	10640	10920	11200		
S					4300	4480	4650	4830	5000	5170	5340	5520	5690	5860	6030	6200	6360	6530	6700
D					8090	8420	8750	9070	9400	9730	10050	10370	10690	11010	11330	11650	11970	12280	12600
S			3670	3830	4000	4160	4320	4480	4650	4810	4970	5130	5280	5440	5600				
D			6940	7260	7570	7870	8180	8490	8790	9100	9400	9700	10000	10300	10600				
S			3960	4130	4300	4470	4640	4810	4980	5150	5320	5490	5660	5830	6000				
D			7300	7600	7900	8200	8500	8800	9100	9400	9700	10000	10300	10600	10900				
S			4400	4550	4700	4850	5000	5150	5300	5450	5600	5750	5900	6050	6200	6350	6500		
D			7820	8090	8360	8630	8900	9170	9440	9710	9980	10250	10520	10790	11060	11330	11600		
S					5100	5300	5500	5700	5900	6100	6300	6500	6700	6900	7100	7300	7500		
D					8790	9140	9500	9860	10210	10560	10920	11270	11620	11960	12310	12660	13000		
S					5100	5300	5500	5700	5900	6100	6300	6500	6700	6900	7100	7300	7500		
D					8880	9290	9700	10110	10520	10930	11340	11750	12160	12570	12980	13390	13800		









TECHNICAL SPECIFICATIONS

Bead	Series	SIZE	Pattern	Index	Index 2	PR	Type		APPROVED RIMS						Min Dual			Index
22.5	90	9R22.5	GT268	136/134M		14	TL	6.75	6.00;7.50	229	970	456	2959	14.0	259	2240	2120	136 134
22.5	90	10R22.5	GT279 GT688	141/139M 141/139M		14 14	TL TL	7.50	6.75	254	1020	476	3111	14.0 16.0	286	2575	2430	141 139
22.5	90	11R22.5	GT01 GT288 GT679 GT688 GT979	148/144M 148/144M 148/144L 148/144M 148/144L		16 16 16 16 16	TL TL TL TL TL	8.25	7.50	279	1050	493	3203	16.0 14.5 20.5 17.5 10.5	314	3150	2800	148 144
22.5	90	11R22.5	GT276 GT279 GT867 GT879	148/145M 148/145M 148/145J 148/145M		16 16 16 16	TL TL TL TL	8.25	7.50	279	1050	493	3203	17.5 17.0 19.5 17.0	314	3150	2900	148 145
22.5	90	12R22.5	GT276 GT288 GT659+ GT679 GT688 GT879	152/148L 152/148M 152/148L 152/148L 152/148M 152/148M		16 16 16 16 16 16	TL TL TL TL TL TL	9.00	8.25	300	1084	507	3306	17.5 15.6 23.0 20.5 17.5 17.5	338	3550	3150	152 148
22.5	90	13R22.5	GT01 GT276 GT676 GT686	154/150L 154/150L 154/150K 154/150K	(156/150K) (156/150G) (156/150G)		TL TL TL TL	9.75	9.00	320	1124	521	3428	17.0 17.5 20.5 24.0	360	3750 (4000)	3350 (3350)	154 150
22.5	80	275/80R22.5	GT659+	149/146L		16	TL	8.25	7.50	276	1012	473	3087	23.5	311	3250	3000	149 146
22.5	80	295/80R22.5	GT276 GT279 GT629 GT659+ GT679 GT688 GT867 GT879	152/148K 152/148M 152/148M 152/148M 152/148M 152/148M 152/148J 152/148M		16 16 16 16 16 16 16 16	TL TL TL TL TL TL TL TL	9.00	8.25	298	1044	487	3184	17.5 17.0 17.9 23.5 20.5 16.5 19.0 17.0	335	3550	3150	152 148
22.5	80	315/80R22.5	GT01 GT276 GT279 GT679 GT688 GT879	154/151L 154/151K 154/151M 154/151M 154/151M 154/151M	(156/151K) (156/151J) (156/151L) (156/151L) (156/151L) (156/151L)	18 18 18 18 18 18	TL TL TL TL TL TL	9.00	9.75	312	1076	500	3282	17.0 18.5 17.0 20.5 17.5 17.0	351	3750 (4000)	3450 (3450)	154 151
22.5	80	315/80R22.5	GT659	154/150M	(156/150L)	18	TL	9.00	9.75	312	1076	500	3282	23.5	351	3750 (4000)	3350 (3350)	154 150
22.5	80	315/80R22.5	GT676 GT686	156/150K 156/150K		18 18	TL TL	9.00	9.75	312	1076	500	3282	20.5 23.5	351	4000	3350	156 150 153
22.5	75	295/75R22.5	GT679	144/141L		14	TL	9.00	8.25	298	1014	474	3093	20.5	335	2800	2575	144 141

Load Capacity by AXLE(kg) and PRESSURE(bar)

	"S=Single D=Dual"	4.5	4.75	5	5.25	5.5	5.75	6	6.25	6.5	6.75	7	7.25	7.5	7.75	8	8.25	8.5	8.75	9
	S		3160	3310	3460	3610	3750	3900	4050	4190	4340	4480								
	D		5980	6260	6550	6830	7100	7380	7660	7930	8210	8480								
	S			3350	3550	3750	3950	4150	4350	4550	4750	4950	5150							
	D			6480	6840	7200	7560	7920	8280	8640	9000	9360	9720							
	S			4140	4320	4500	4680	4860	5040	5220	5400	5580	5760	5940	6120	6300				
	D			7340	7670	7990	8320	8650	8970	9290	9610	9930	10250	10570	10880	11200				
	S			4140	4320	4500	4680	4860	5040	5220	5400	5580	5760	5940	6120	6300				
	D			7640	7970	8300	8630	8960	9290	9620	9950	10280	10610	10940	11270	11600				
	S					4700	4900	5100	5300	5500	5700	5900	6100	6300	6500	6700	6900	7100		
	D					8520	8860	9200	9540	9880	10220	10560	10900	11240	11580	11920	12260	12600		
	S					5350	5570	5790	6010	6220	6440	6650	6860	7080	7290	7500				
	D					9560	9950	10340	10730	11120	11500	11880	12260	12640	13020	13400				
	S					4390	4570	4750	4930	5110	5280	5460	5630	5810	5980	6150	6330	6500		
	D					8110	8440	8770	9100	9430	9750	10080	10400	10720	11040	11360	11680	12000		
	S					4700	4900	5100	5300	5500	5700	5900	6100	6300	6500	6700	6900	7100		
	D					8520	8860	9200	9540	9880	10220	10560	10900	11240	11580	11920	12260	12600		
	S					5070	5280	5480	5690	5890	6090	6300	6500	6700	6900	7100	7500			
	D					9330	9710	10090	10460	10840	11210	11590	11960	12330	12700	13070	13800			
	S					5070	5280	5480	5690	5890	6090	6300	6500	6700	6900	7100	7500			
	D					9060	9430	9790	10160	10530	10890	11250	11610	11970	12330	12690	13400			
	S					5410	5630	5850	6070	6280	6500	6720	6930	7150	7360	7580	7790	8000		
	D					9060	9430	9790	10160	10530	10890	11250	11610	11970	12330	12690	13400			
	D					9440	9770	10100	10430	10760	11090	11420	11750	12080	12410	12740	13070	13370	14280	14600
	S							4320	4480	4650	4810	4970	5130	5280	5440	5600				
	D							7530	7810	8090	8370	8650	8930	9200	9480	10300				

TECHNICAL SPECIFICATIONS

Bead	Series	SIZE	Pattern	Index	Index 2	PR	Type		APPROVED RIMS	 mm	 mm	 mm	 mm	 mm	Min Dual	 kg	 max	 kg	Index
22.5	70	255/70R22.5	GT279 GT979	140/137M 140/137L		16	TL	7.50	6.75;8.25	255	930	435	2837	14.0 10.5	287	2500	2300	140 137	
22.5	70	275/70R22.5	GT279 GT676 GT867	148/145M 148/145K 148/145J	(152/148E)	16 16 16	TL TL TL	8.25	7.50	276	958	446	2922	15.0 21.0 19.0	311	3150 (3550)	2900 (3150)	148 145	
22.5	70	315/70R22.5	GT279 GT659+ GT679	154/150L 154/150L 154/150L	(152/148M) (152/148M) (152/148M)	18 18 18	TL TL TL	9.00	9.75	312	1014	467	3093	14.5 23.5 20.5	351	3750 (3550)	3350 (3150)	154 150	
22.5	65	385/65R22.5	GT269 GT876 GT888 GT978 GT988+	158L 158L 158L 158L 158L	(160K) (160K) (160K) (160K) (160K)	18 18 18 18 18	TL TL TL TL TL	11.75	12.25	389	1072	501	3248	14.0 17.9 15.0 15.5 14.0	-	4250 (4500)	-	158 160	
22.5	65	425/65R22.5	GT876	165 K		20	TL	13.00	11.75;12.25	430	1124	525	3406	18.7	-	5150	-	165	
22.5	65	445/65R22.5	GT876	169 K		20	TL	14.00	12.25;13.00	454	1150	537	3485	18.7	-	5800	-	169	
22.5	55	385/55R22.5	GT259	158L	(160K)	18	TL	11.75		389	996	465	3018	14.5	-	4250 (4500)	-	158	
22.5	55	385/55R22.5	GT988+	160K	(158L)	20	TL	11.75		389	996	465	3018	15.0	-	4500 (4250)	-	160	
24	100	12.00R24	GT01 GT276 GT676 GT879	156/153K 156/153K 156/153K 156/153K		18 18 18 18	TT TT TT TT	8.5	8.50;9.00	315	1226	572	3739	17.0 17.0 20.5 14.5	344	4000	3650	156 153	
24.5	90	11R24.5	GT679	149/146L		16	TL	8.25	7.50	279	1104	516	3367.2	20.5	314	3250	3000	149 146	

Load Capacity by AXLE(kg) and PRESSURE(bar)

	"S=single D=Dual"	4.5	4.75	5	5.25	5.5	5.75	6	6.25	6.5	6.75	7	7.25	7.5	7.75	8	8.25	8.5	8.75	9
	S D					3200 6000	3380 6320	3560 6640	3740 6960	3920 7280	4100 7600	4280 7920	4460 8240	4640 8560	4820 8880	5000 9200				
	S D							4260 8000	4430 8300	4600 8600	4770 8900	4940 9200	5110 9500	5280 9800	5450 10100	5620 10400	5790 10700	5960 11000	6130 11300	6300 11600
	S D							5100 9200	5300 9550	5500 9900	5700 10250	5900 10600	6100 10950	6300 11300	6500 11650	6700 12000	6900 12350	7100 12700	7300 13050	7500 13400
	S S					5620 5620	5860 5860	6100 6100	6340 6340	6580 6580	6820 6820	7060 7060	7300 7300	7540 7540	7780 7780	8020 8020	8260 8260	8500 8500	8750 8750	9000 9000
	S					6940	7220	7500	7780	8060	8340	8620	8900	9180	9460	9740	10020	10300		
	S							8000	8300	8600	8900	9200	9500	9800	10100	10400	10700	11000	11300	11600
	S					5900	6140	6380	6620	6860	7100	7330	7570	7800	8030	8270	8500	8730	8500	
	S					6250	6500	6760	7010	7260	7510	7760	8010	8260	8510	8750	9000	9250	9490	9000
	S D			5470 10090	5700 10500	5930 10910	6160 11320	6390 11730	6620 12140	6850 12550	7080 12960	7310 13370	7540 13780	7770 14190	8000 14600					
	S D			4390 8110	4570 8440	4750 8770	4930 9100	5110 9430	5280 9750	5460 10080	5630 10400	5810 10720	5980 11040	6150 11360	6330 11680	6500 12000				

Regrooving of Radial Tyre

GT279

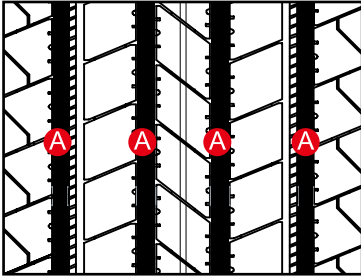

Max.regrooving depth: 3mm

Size	A(mm)
245/70R19.5	6-8
285/70R19.5	
10.00R20	6-8
11.00R20	6-8
12.00R20	
10R22.5	6-8
11R22.5	
255/70R22.5	6-8
275/70R22.5	7-9
315/70R22.5	7-9
295/80R22.5	7-9
315/80R22.5	7-9

GT288

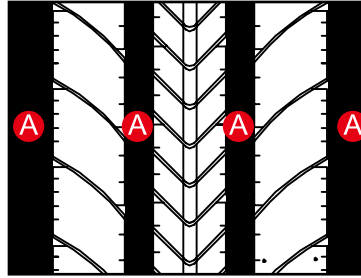

Max.regrooving depth: 3mm

Size	A(mm)
11R22.5	7-9
12R22.5	7-9
295/80R22.5	7-9
315/80R22.5	7-9

GT276

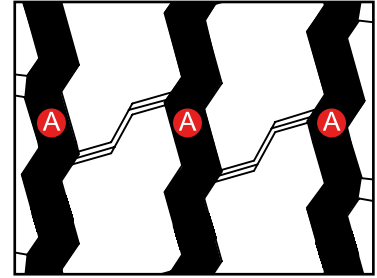

Max.regrooving depth: 3mm

Size	A(mm)
11R22.5	7-9
12R22.5	7-9
13R22.5	7-9
295/80R22.5	7-9
315/80R22.5	7-9
12.00R24	7-9

GT259

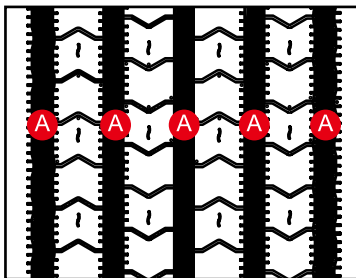

Max.regrooving depth: 3mm

Size	A(mm)
385/55R22.5	9-11

GT268

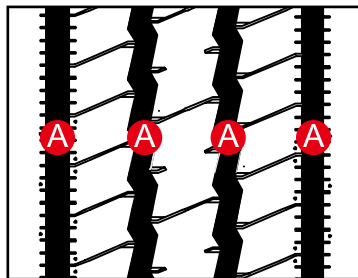

Max.regrooving depth: 3mm

Size	A(mm)
215/75R17.5	6-8
235/75R17.5	6-8
9R22.5	6-8

GT269

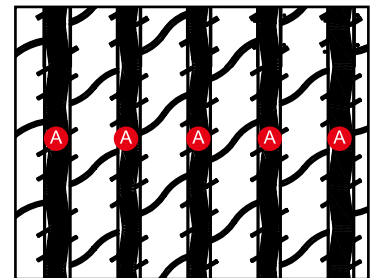

Max.regrooving depth: 3mm

Size	A(mm)
385/65R22.5	9-11

Regrooving of Radial Tyre

GT879

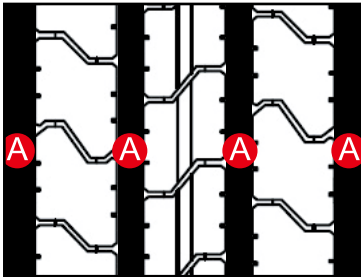

Max.regrooving depth: 3mm

Size	A(mm)
215/75R17.5	7-9
235/75R17.5	7-9
265/70R19.5	7-9
10.00R20	7-9
11.00R20	7-9
12.00R20	7-9
11R22.5	7-9
12R22.5	8-10
295/80R22.5	8-10
315/80R22.5	8-10
12.00R24	8-10

GT01

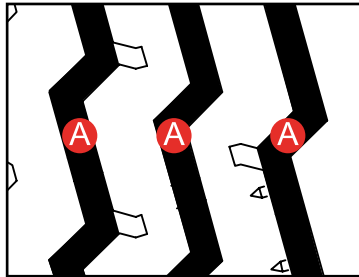

Max.regrooving depth: 3mm

Size	A(mm)
9.00R20	8-10
10.00R20	8-10
11.00R20	8-10
12.00R20	8-10
11R22.5	8-10
13R22.5	8-10
315/80R22.5	8-10
12.00R24	8-10

GT867

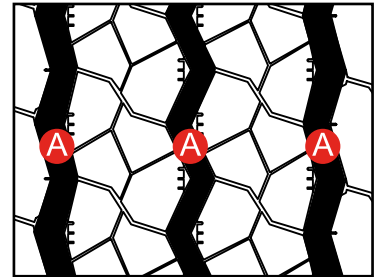

Max.regrooving depth: 3mm

Size	A(mm)
11R22.5	7-9
275/70R22.5	7-9
295/80R22.5	7-9

GT629

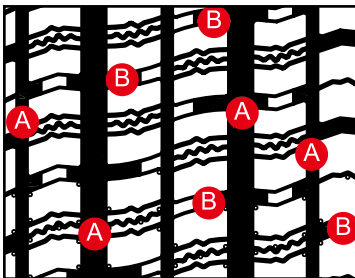

Max.regrooving depth: 3mm

Size	A(mm)	B(mm)
295/80R22.5	7-9	3-5

GT679

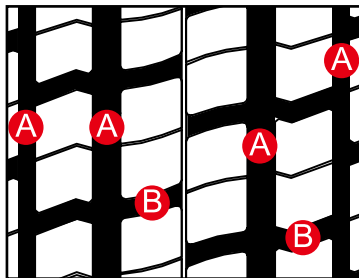

Max.regrooving depth: 3mm

Size	A(mm)	B(mm)
215/75R17.5	7-9	3-5
235/75R17.5	7-9	3-5
265/70R19.5	7-9	3-5
285/70R19.5	7-9	3-5
11R22.5	7-9	3-5
12R22.5	7-9	3-5
315/70R22.5	7-9	3-5
295/80R22.5	7-9	3-5
315/80R22.5	7-9	3-5

GT659/659+

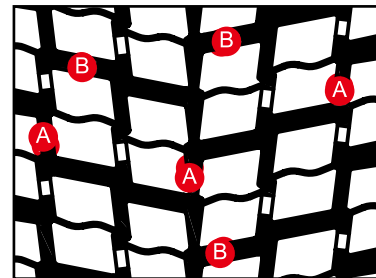

Max.regrooving depth: 3mm

Size	A(mm)	B(mm)
12R22.5	8-10	7-9
315/70R22.5	8-10	7-9
275/80R22.5	8-10	7-9
295/80R22.5	7-9	3-5
315/80R22.5	8-10	7-9

Regrooving of Radial Tyre

GT678

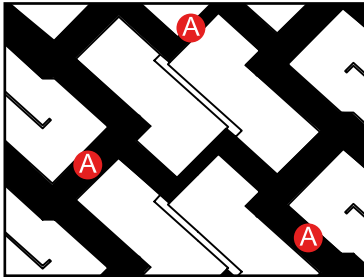

Max.regrooving depth: 3mm

Size	A(mm)
7.50R16 LT	7-9
8.25R16 LT	7-9
245/70R19.5	7-9
265/70R19.5	7-9
285/70R19.5	7-9
295/80R22.5	7-9

GT686

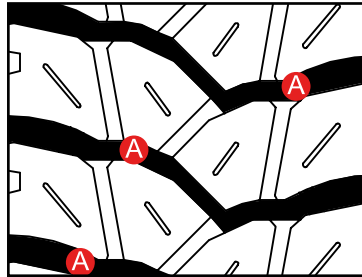

Max.regrooving depth: 3mm

Size	A(mm)
13R22.5	10-12
315/80R22.5	10-12

GT688

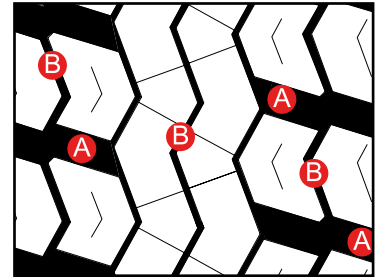

Max.regrooving depth: 3mm

Size	A(mm)	B(mm)
10R22.5	8-10	5-7
11R22.5	8-10	5-7
12R22.5	8-10	5-7
295/80R22.5	8-10	5-7
315/80R22.5	8-10	5-7

GT676

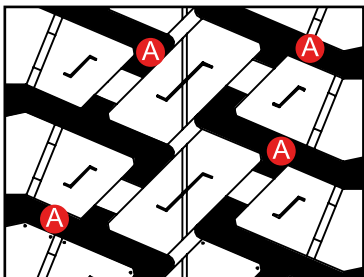

Max.regrooving depth: 3mm

Size	A(mm)
13R22.5	10-12
275/70R22.5	10-12
315/80R22.5	10-12
12.00R24	10-12

GT669

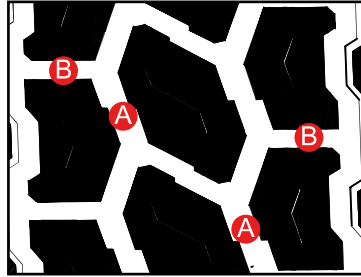

Max.regrooving depth: 3mm

Size	A(mm)
10.00R20	
11.00R20	
12.00R20	

GT988+

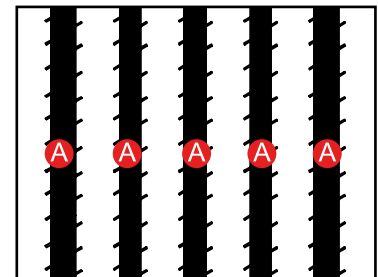

Max.regrooving depth: 3mm

Size	A(mm)
245/70R17.5	7-9
215/75R17.5	7-9
235/75R17.5	7-9
285/70R19.5	7-9
385/55R22.5	9-11
385/65R22.5	9-11

Regrooving of Radial Tyre

GT888

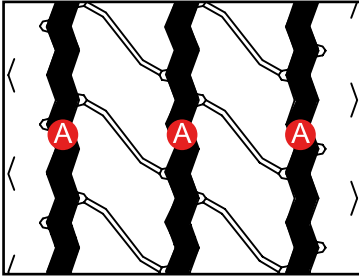

Max.regrooving depth: 3mm

Size	A(mm)
385/65R22.5	9-11

GT979

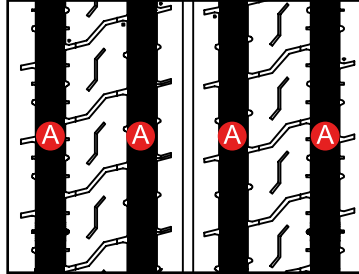

Max.regrooving depth: 2.5mm

Size	A(mm)
11R22.5	7-9
255/70R22.5	7-9

GT978

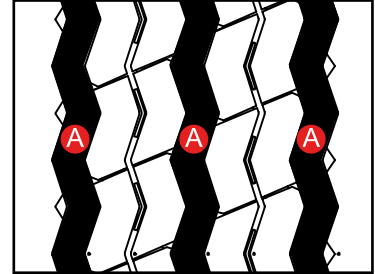

Max.regrooving depth: 3mm

Size	A(mm)
385/65R22.5	8-10

GT876

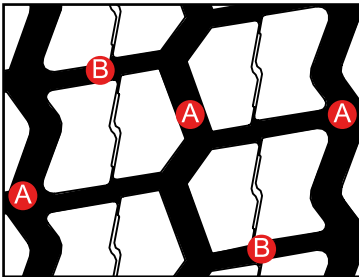

Max.regrooving depth: 3mm

Size	A(mm)	B(mm)
385/65R22.5	10-12	7-9
425/68R22.5	10-12	7-9
445/65R22.5	10-12	7-9

CONTACT

Subsidiary contact details

Sales contact

GITI TIRE contact

GITI TIRE (Europe) B.V.

Oscar Romerolaan 11, 1216 TJ Hilversum
The Netherlands

Tel: 0031 (0)35 6282644

Fax: 0031 (0)35 6409668