



Bär Cargolift Standard S2 Tailor-made for light commercial vehicles

Bär Cargolift –
more than just a taillift

Bär Cargolifts have become an essential part of distribution and general cargo handling. Reliable operation, high lifespan, low dead weight and quick and easy fitment are just some of the many benefits.

For the Renault Master/ Opel Movano a special fitment plate is available that enables a quick and secure fitment.

The well known stability of the Bär Cargolift is also guaranteed by this fitment plate.

The ground clearance is exceptionally good.

BC 751S2



Master



Movano

 **BÄR**
Cargolift®

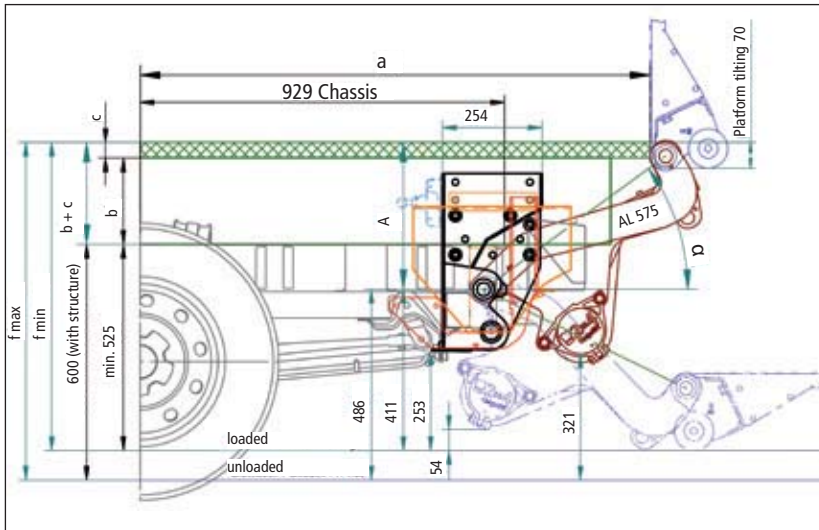
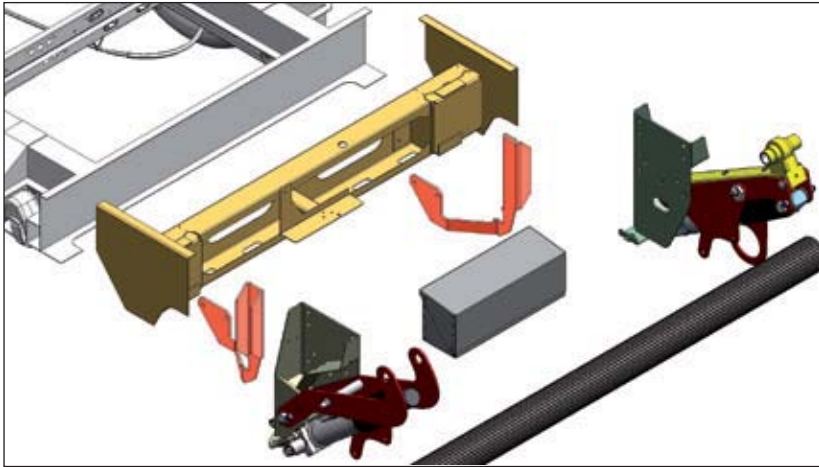

Efficient trolley transport with trolley stop 2ad or 2rd for two trolleys.



The BC 750S2 is stable and consequent also suitable for pallets. Platform safety with TracGrip and SideGrip.

The BC 751S2 is identically to the BC 750S2 from a technical point of view.

The difference to the BC 750S2 consists in:

- Larger distance between supporting arms
- Different hose lengths
- Power pack mounted on fitment plate
- Prefitted as standard

Quick fitment

The under run bar of the Renault Master / Opel Movano has to be cut on both sides. Thereafter the Cargolift can be fixed with the fitment plate on the under run bar. The Cargolift can be positioned on the fitment plate and can then be adapted for the overhang. The two hangers serve for the perfect distribution of forces as they are bolted to the chassis and the subframe.

Fitment for smallest overhangs

b + c	a	A	α
210 ... 250	1250 ... 1220	322 ... 365	30° - 35°
250 ... 290	1220 ... 1195	365 ... 405	35° - 40°
290 ... 327	1195 ... 1175	405 ... 442	40° - 45°
327 ... 360	1175 ... 1150	442 ... 475	40° - 50°

Fitment for largest overhangs

b + c	a	A	α
210 ... 250	1410 ... 1385	322 ... 365	30° - 35°
250 ... 290	1385 ... 1355	365 ... 405	35° - 40°
290 ... 327	1355 ... 1320	405 ... 442	40° - 45°
327 ... 360	1320 ... 1285	442 ... 475	45° - 50°

In case of larger overhangs as mentioned, we use the BC 750S2. Fitment directly on chassis. See drawing T1193.000

Load capacity

BC type	Capacity kg	Load distance mm	Load moment kNm
750S2	750	600	4,5

Aluminium platforms Cargolift weight for platform width 2100 mm

BC type	BAplan30VLL Platform height mm	Weight kg	
		Fitment plate without	with
751S2	1410	186	221
	1610	194	229
	1810	202	237